



2SD313

NPN SILICON TRANSISTOR

NPN EPITAXIAL PLANAR TRANSISTOR

■ DESCRIPTION

The UTC **2SD313** is designed for use in general purpose amplifier and switching applications.

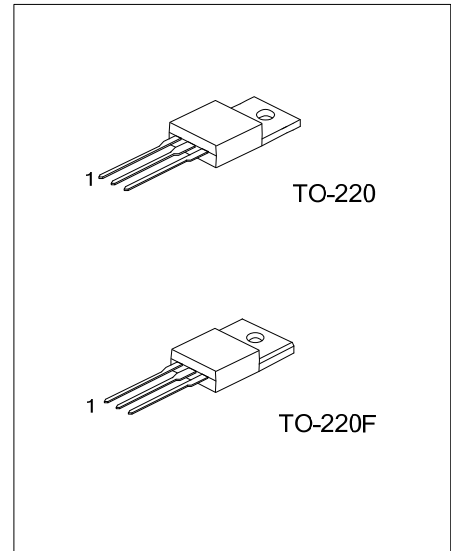

■ ORDERING INFORMATION

Ordering Number		Package	Pin Assignment			Packing
Lead Free	Halogen Free		1	2	3	
2SD313L-x-TA3-T	2SD313G-x-TA3-T	TO-220	B	C	E	Tube
2SD313L-x-TF3-T	2SD313G-x-TF3-T	TO-220F	B	C	E	Tube

<p>2SD313L-x-TA3-T</p> <p>(1)Packing Type (2)Package Type (3)Rank (4)Lead Free</p>	<p>(1) T: Tube (2) TA3: TO-220, TF3: TO-220F (3) x: refer to Classification of h_{FE} (4) G: Halogen Free, L: Lead Free</p>
--	--

■ ABSOLUTE MAXIMUM RATINGS

PARAMETER	SYMBOL	RATINGS	UNIT
Collector-Base Voltage	V_{CBO}	60	V
Collector-Emitter Voltage	V_{CEO}	60	V
Emitter-Base Voltage	V_{EBO}	5	V
Collector Current	I_C	3	A
Collector Dissipation	P_C	1.75	W
Junction Temperature	T_J	+150	°C
Storage Temperature	T_{STG}	-55 ~ +150	°C

Note: Absolute maximum ratings are those values beyond which the device could be permanently damaged. Absolute maximum ratings are stress ratings only and functional device operation is not implied.

■ ELECTRICAL CHARACTERISTICS($T_A=25^\circ\text{C}$)

PARAMETER	SYMBOL	TEST CONDITIONS	MIN	TYP	MAX	UNIT
Collector-Base Breakdown Voltage	BV_{CBO}	$I_C=1\text{mA}$	60			V
Collector-Emitter Breakdown Voltage	BV_{CEO}	$I_C=10\text{mA}$	60			V
Emitter-Base Breakdown Voltage	BV_{EBO}	$I_E=100\mu\text{A}$	5			V
Collector Cut-Off Current	I_{CBO}	$V_{CB}=20\text{V}, I_E=0$			0.1	mA
Emitter Cut-Off Current	I_{EBO}	$V_{EB}=4\text{V}, I_C=0$			1.0	mA
Collector-Emitter Saturation Voltage	$V_{CE(SAT)}$	$I_C=2\text{A}, I_B=0.2\text{A}$			1.0	V
Base-Emitter On voltage	$V_{BE(ON)}$	$V_{CE}=2\text{V}, I_C=1\text{A}$			1.5	V
Gain Band width Product	f_T	$V_{CE}=5\text{V}, I_C=0.5\text{A}$		8		MHz
DC Current Gain	h_{FE}	$I_C=1\text{A}, V_{CE}=2\text{V}$	40		320	
		$I_C=0.1\text{A}, V_{CE}=2\text{V}$	40			

■ CLASSIFICATION ON h_{FE}

RANK	C	D	E	F
RANGE	40-80	60-120	100-200	160-320

TYPICAL CHARACTERISTICS

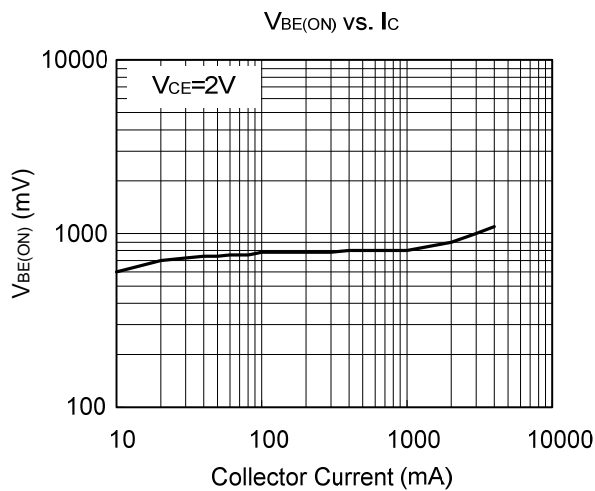
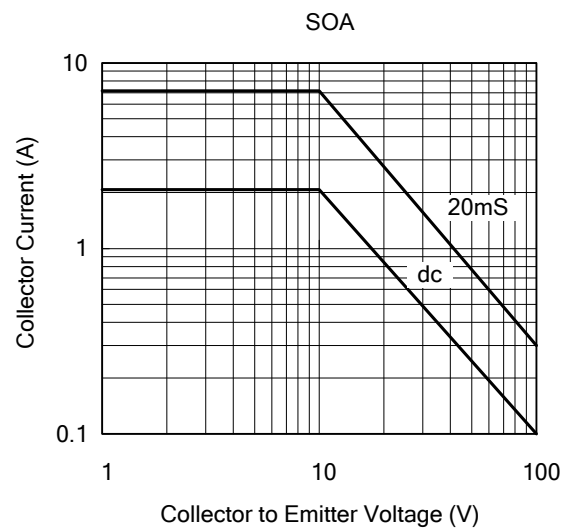
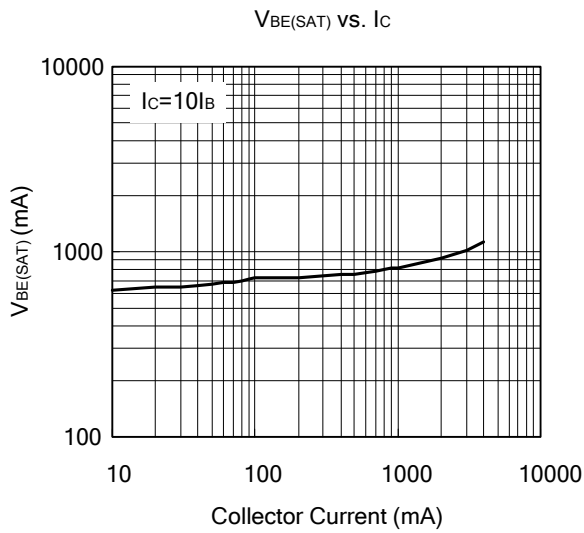
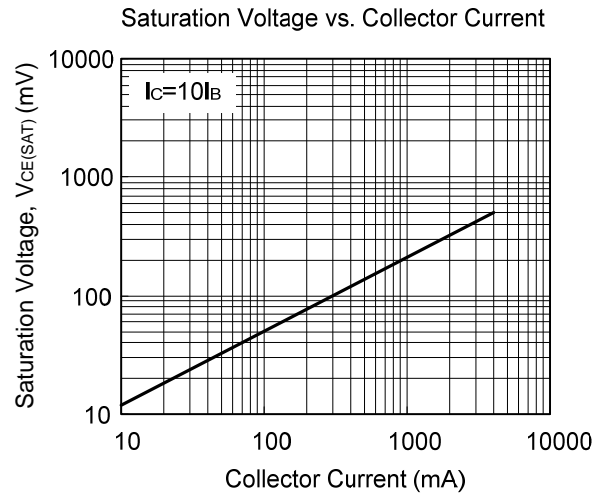
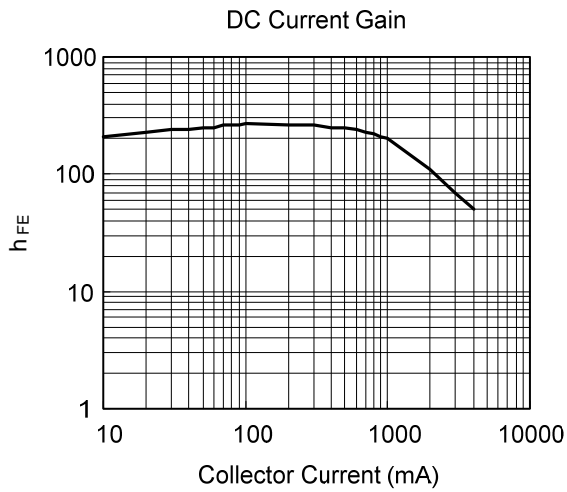

UTC assumes no responsibility for equipment failures that result from using products at values that exceed, even momentarily, rated values (such as maximum ratings, operating condition ranges, or other parameters) listed in products specifications of any and all UTC products described or contained herein. UTC products are not designed for use in life support appliances, devices or systems where malfunction of these products can be reasonably expected to result in personal injury. Reproduction in whole or in part is prohibited without the prior written consent of the copyright owner. The information presented in this document does not form part of any quotation or contract, is believed to be accurate and reliable and may be changed without notice.